

MINIDIGGER

ES 90ZT

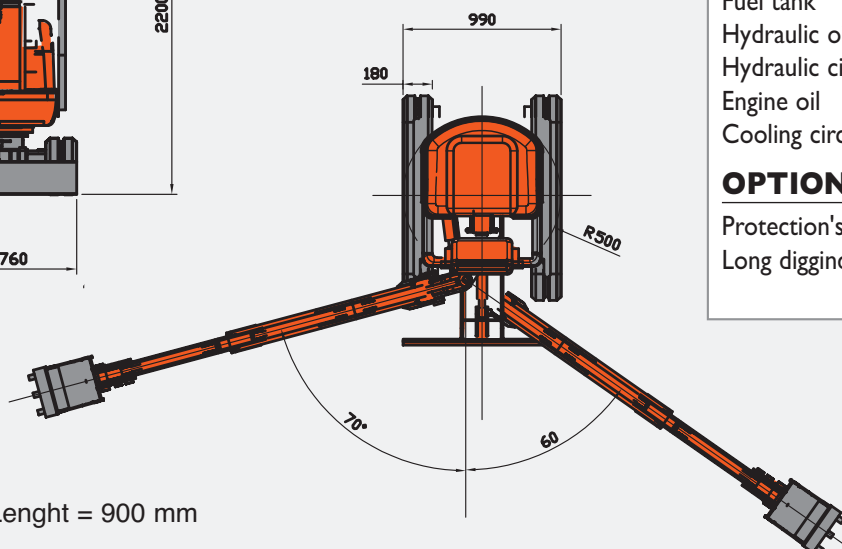
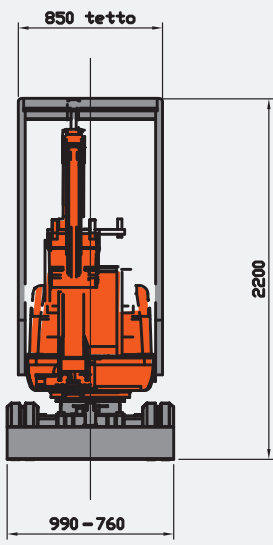
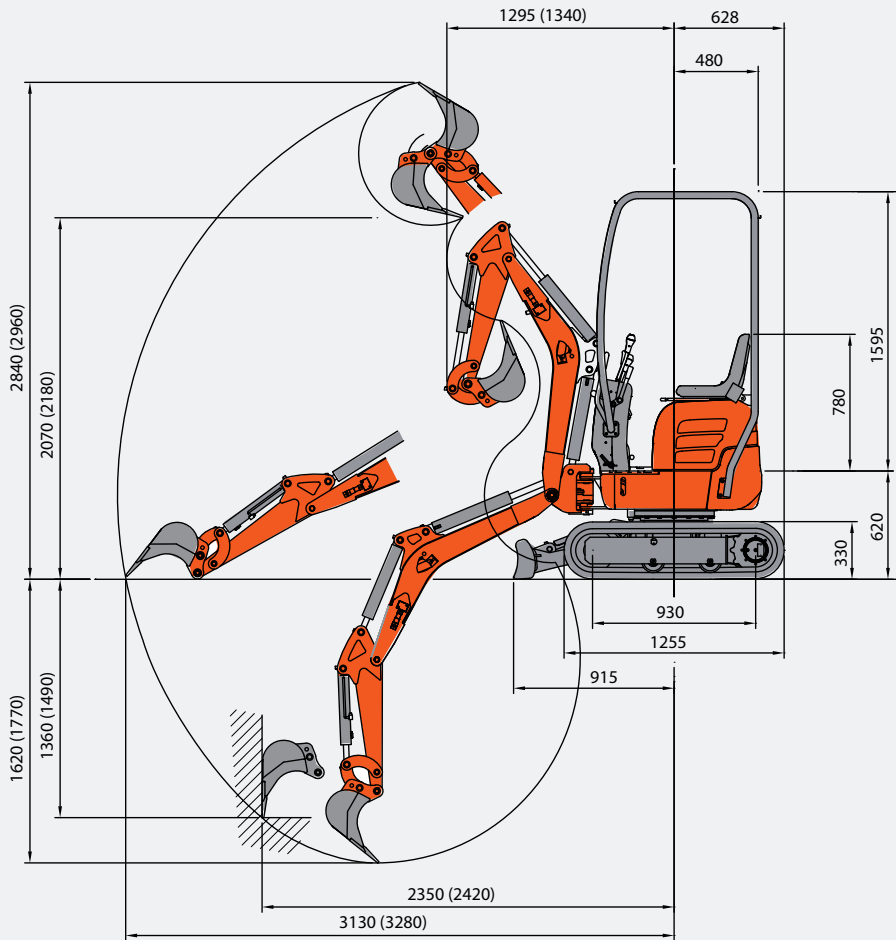

(..) = long arm Length = 900 mm

TEHCNICAL SPECIFICATIONS

WEIGHT

Weight	kg	960
(with rubber tracks and NO roof)		
Weight with roof	kg	1000
Type	ZT – Zero Tail	
Translation's speed 1°-2°	km/h	1,8 – 3,8
Rotation's speed	rpm	9,5

ENGINE

Model	YANMAR-2TNV 70	
Power (2450 rpm)	kW (Hp)	7,6 (10)
Displacement	cc	570
Number of cylinders	2	

HYDRAULIC CIRCUIT

Type	open center	
Pump	n.	2 gear
Pump displacement	cc	4,8- 4,8
Pump flow	lt./min	2x1 1,7
Auxiliary circuit	lt./min	23
Relief pressure	Bar	170

PERFORMANCES & DIMENSIONS

Width min - max	mm	760 - 990
Total lenght (with outstretched arm)	mm	3130 - (3280)
Rear turning radius	mm	499
Max digging depth	mm	1620 - (1770)
Max unloading height	mm	2070 - (2180)
Swing	left	60°
	right	70°
Teeth digging power (standard arm) ISO 6015	kgf	1010
Arm digging power (standard arm) ISO 6015	kgf	752

UNDERCARRIAGE

Max width (open-closed)	mm	760-990
Dozer blade (with-without widenings)	mm	760-990
Rubber tracks	mm	180
Nr. of rollers (each side)	2	
Ground pressure	kg/cm ²	0,28

FILLINGS

Fuel tank	lt.	10
Hydraulic oil tank.	lt.	9,5
Hydraulic circuit capacity	lt.	15
Engine oil	lt.	1,5
Cooling circuit	lt.	5

OPTIONALS

- Protection's roof TOPS-FOPS Level I
- Long diggind arm (+ 150 mm)



EUROCOMACH[®]

MINIDIGGER

ES 90ZT



10 HP YANMAR-DIESEL 2TNU70 ENGINE
FRONT SERVO-MECHANIC CONTROLS
HYDRAULIC CIRCUIT FOR HAMMER
RUBBER TRACKS
DOZER BLADE

DIGGING DEPTH FROM	1620-1770 mm
TRACKS WIDTH	760-990 mm
MAX DIGGING POWER (BUCKET TEETH)	1010 Kg
WEIGHT (WITHOUT ROOF)	960 Kg
STANDARD BUCKET	300 mm